



# camea

Solutions for **SPEED ENFORCEMENT**

Weigh-In-Motion • Dimension-In-Motion • Speed Enforcement • Traffic Counters • Smart Cameras

# CAMEA Speed Enforcement

Field-proven systems for safer roads and calmer environment.



Lower Speed



Less Noise



Cleaner Air

# CAMEA Speed Enforcement Advantages



## Fully Automatic Digital System

- No human interference with no possibility of corrupt behavior.
- Violations evaluated and documented automatically and immediately sent to the relevant authorities for fining.



## Various Speed Limits Can Be Set

- Based on the requirements (e.g., night vs day).
- Based on the vehicle class (e.g., truck vs passenger car).



## High Utility Value

- Drivers timely and conclusively informed of the speed limit and their speed.
- The system can be extended to detect other traffic offenses.

# Achievements of Speed Enforcement

The number of speeding drivers is typically reduced by around **80 %** within a **FEW MONTHS** after the installation.

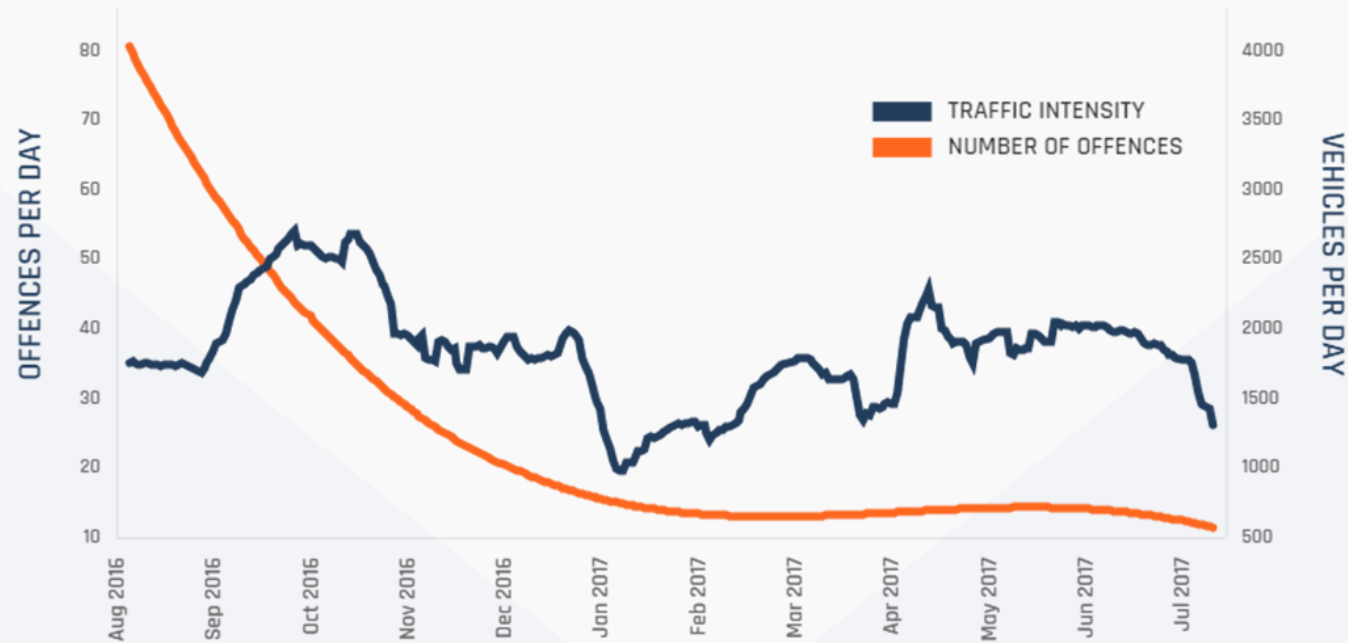

# Speed Enforcement Solutions



## Speed Enablement at WIM stations

- Making use of already installed in-road sensors (weighing sensors or loops).
- Only additional SW licenses are necessary, no need to install new HW.



## Radar Speed Measurement

- Speed enforcement in the immediate area around the radar (up to 100 m).
- Suitable for locations with a higher risk of accidents and dangerous situations.



## Section Speed Measurement

- Speed enforcement over a longer stretch of road (i.e., not just near radar).
- Suitable for locations with the need to ensure the smooth passage of all vehicles.

# We Have Extensive Experience Worldwide

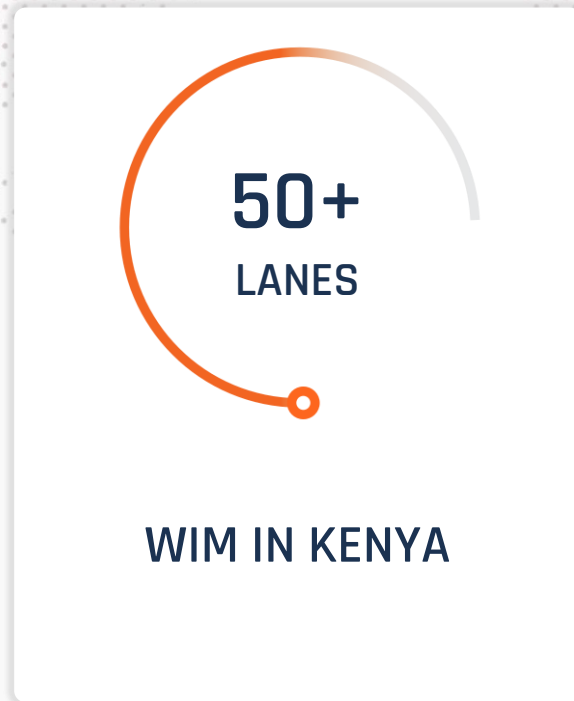
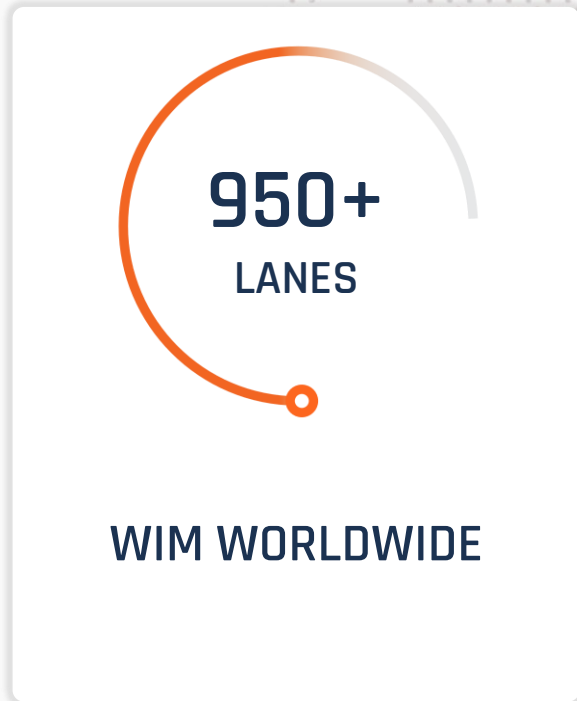

# We Have Extensive Experience Worldwide

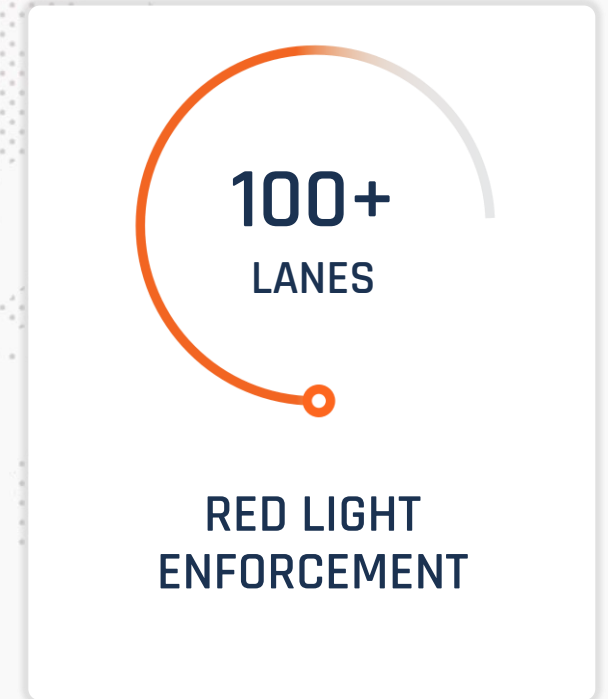
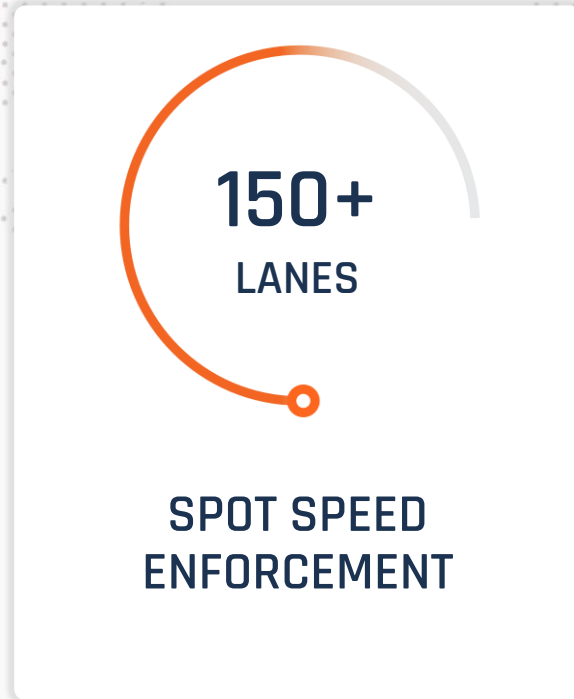
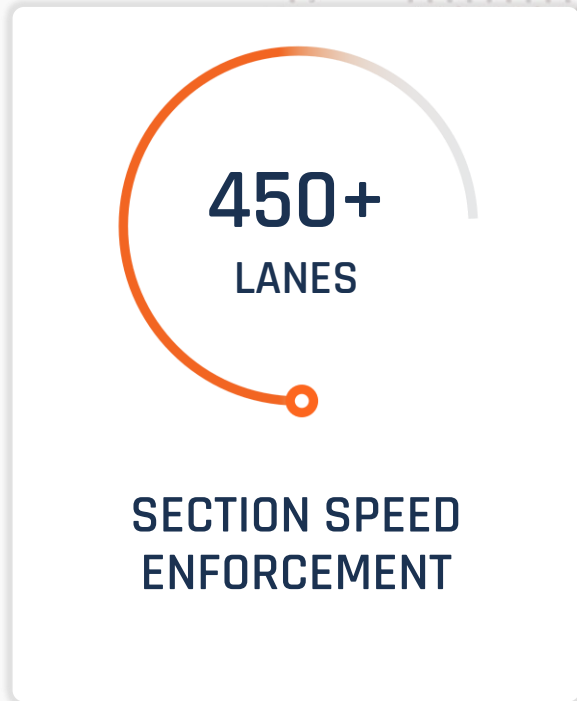

# We Are Experts in Direct Enforcement

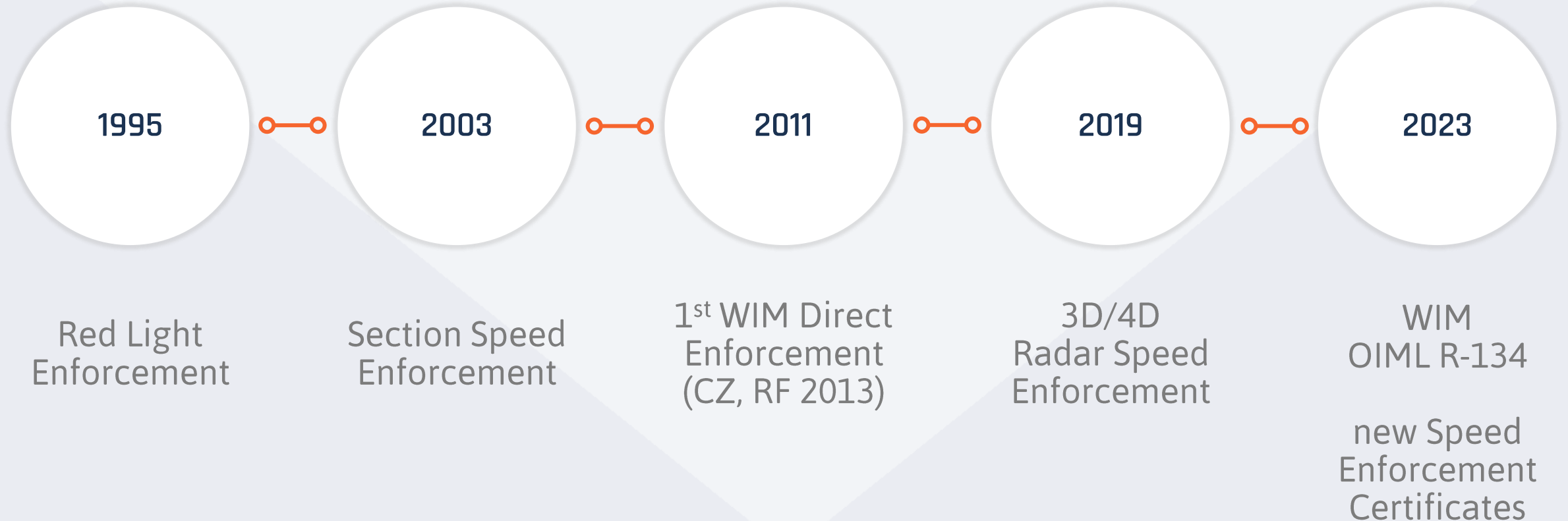

# CAMEA Prague City ITS (CZ)

- City WIM
- Speed Enforcement
- Red Light Enforcement
- Other ITS

# Speed Enablement at WIM Stations

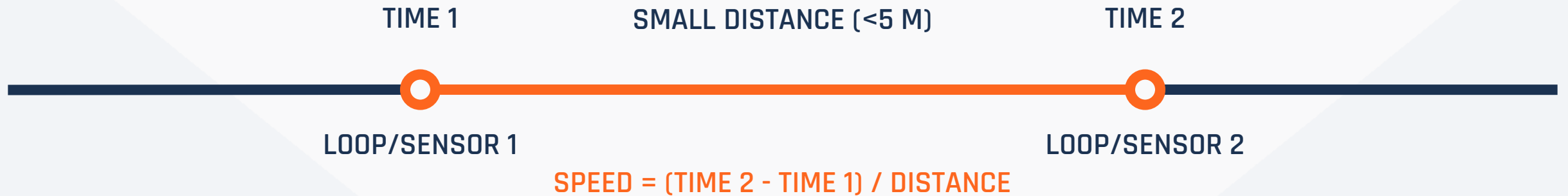

- Additional Requirements: SW license
- Used Technology: Weighing sensors or inductive loops
- Principle: Measurement of the time difference over a known distance between the sensors. The distance is very small and therefore can be determined as current speed.

# Speed Enablement at WIM Stations

Using inductive loops for speed measurement.

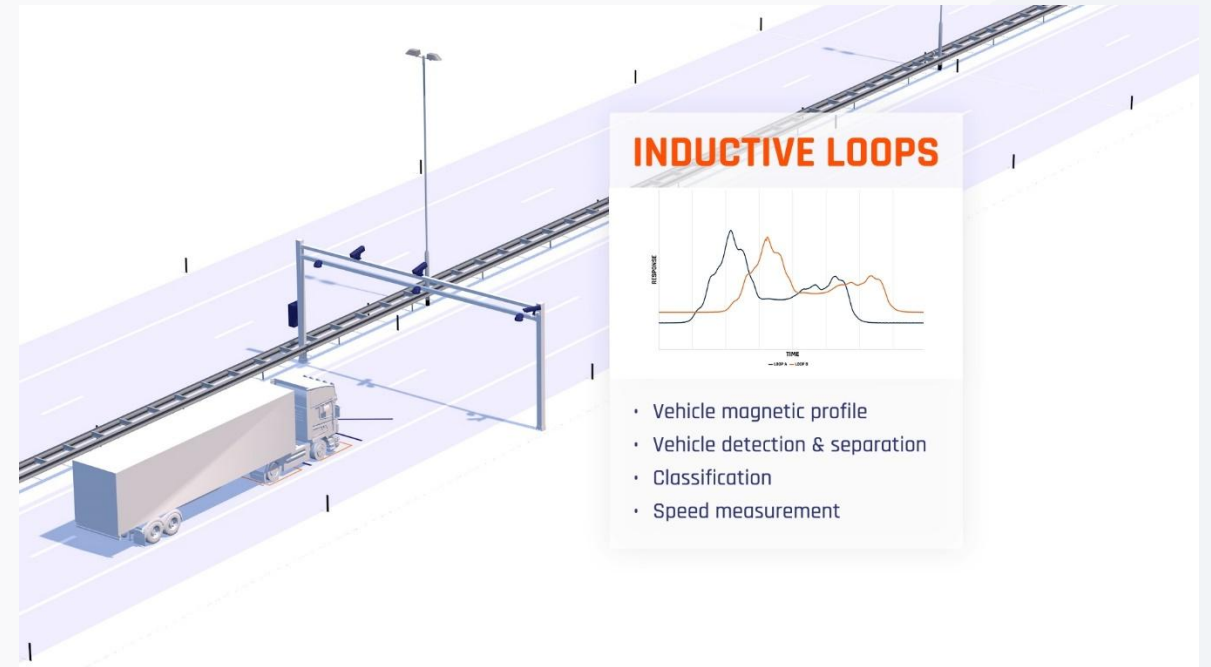
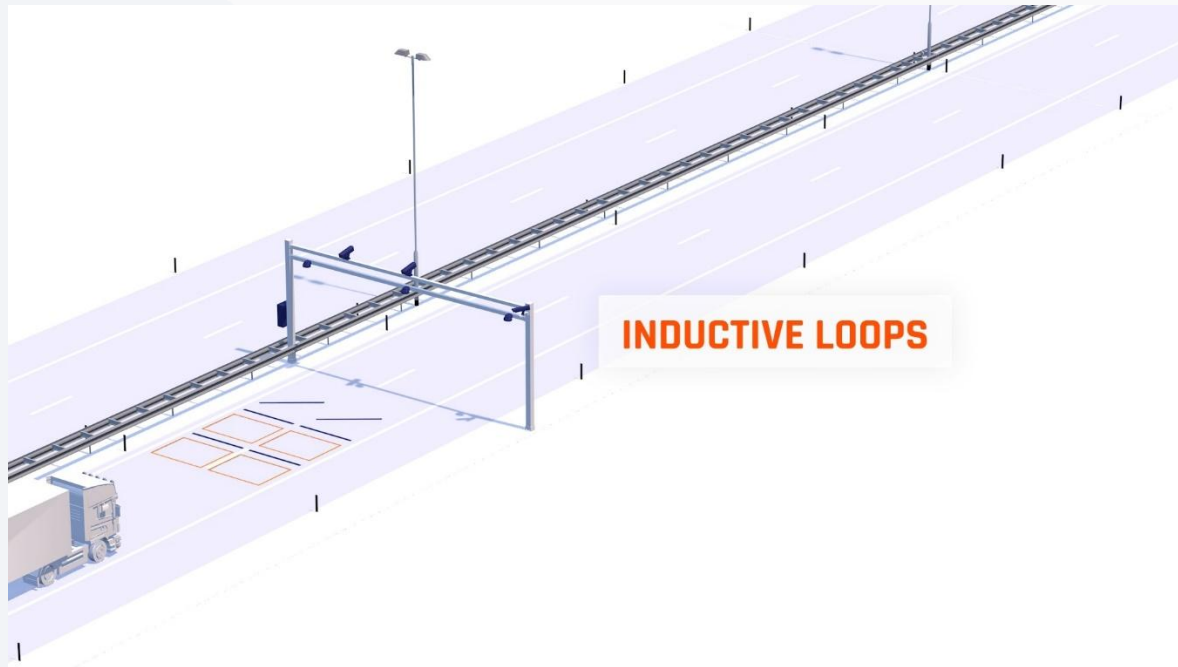

# Speed Enablement at WIM Stations

Using weighing sensors for speed measurement.

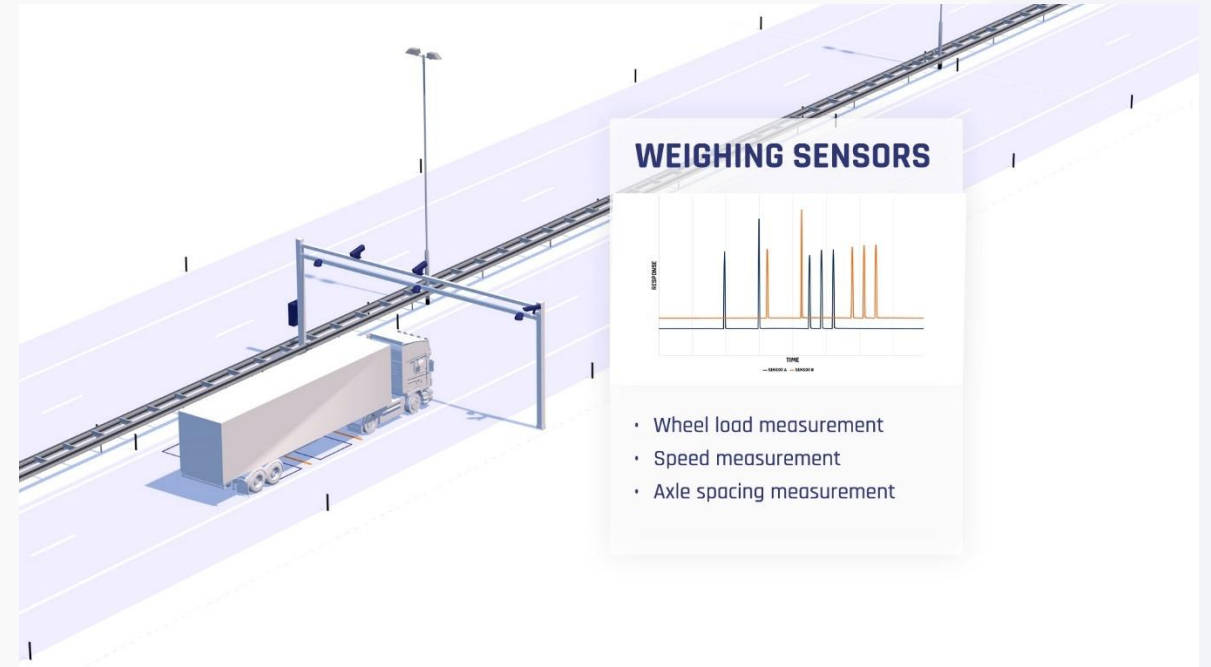
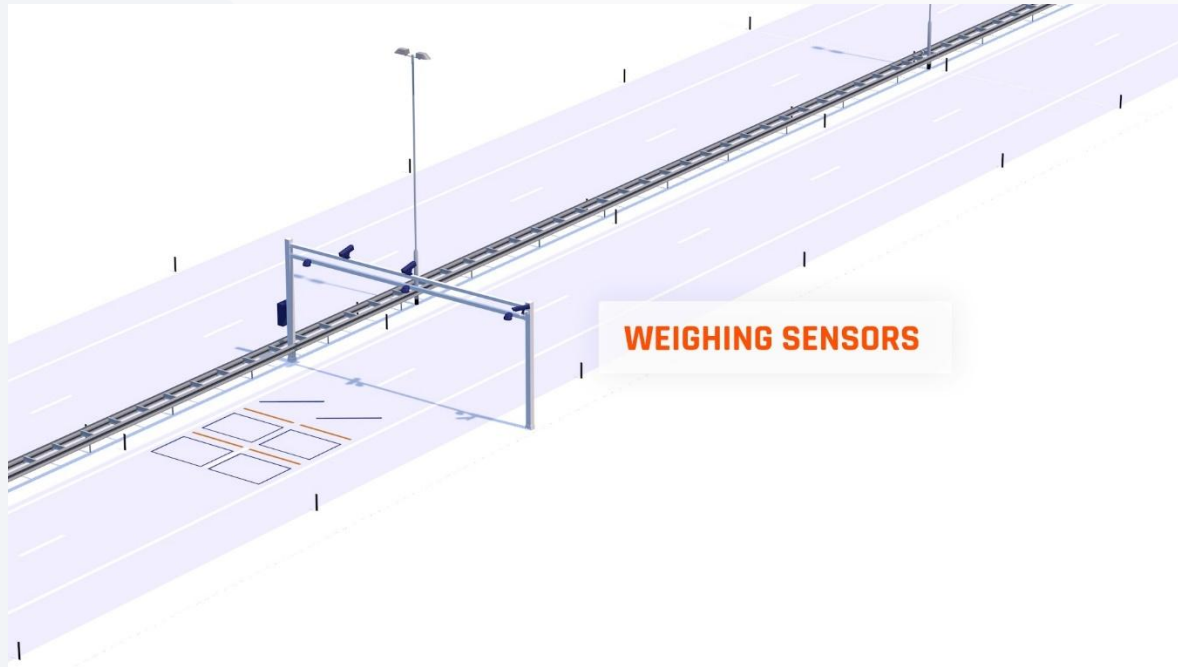

# Speed Enablement at WIM Stations

Making use of the already installed technology by adding a SW module.



# Type Approval

- Speed enforcement using inductive loops.
- First type approved in 2007 in the Czech Republic.
- Currently valid until November 12, 2028.



# Radar Speed Enforcement Overview

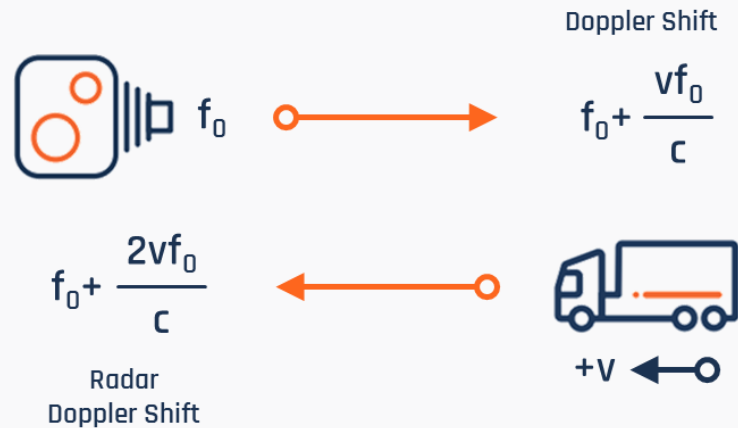

- Additional Requirements: HW (if not already installed) and SW licenses
- Used Technology: ANPR camera, 3D/4D traffic radar
- Principle: Using the radar Doppler Shift to measure the spot (current) speed and vehicle movement tracing to measure the section (average) speed.

# Radar Speed Enforcement Use Cases

Road safety at pedestrian crossings.

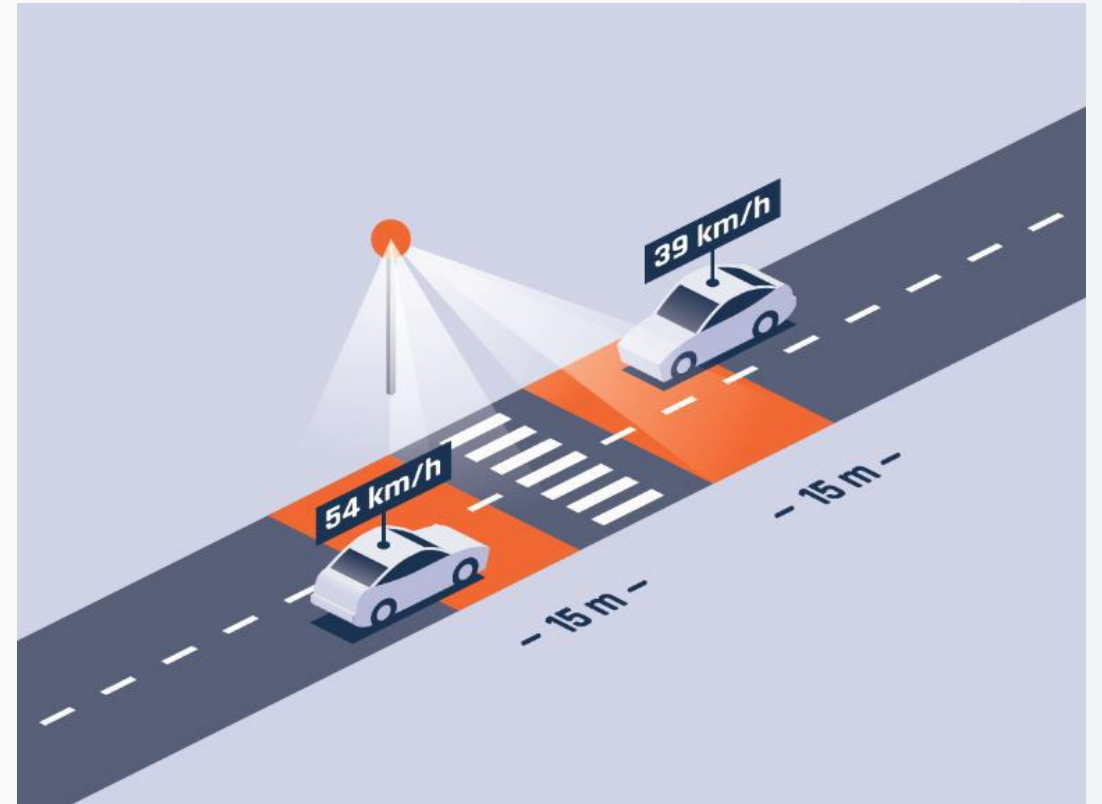

# Radar Speed Enforcement Use Cases

Road safety at pedestrian crossings.

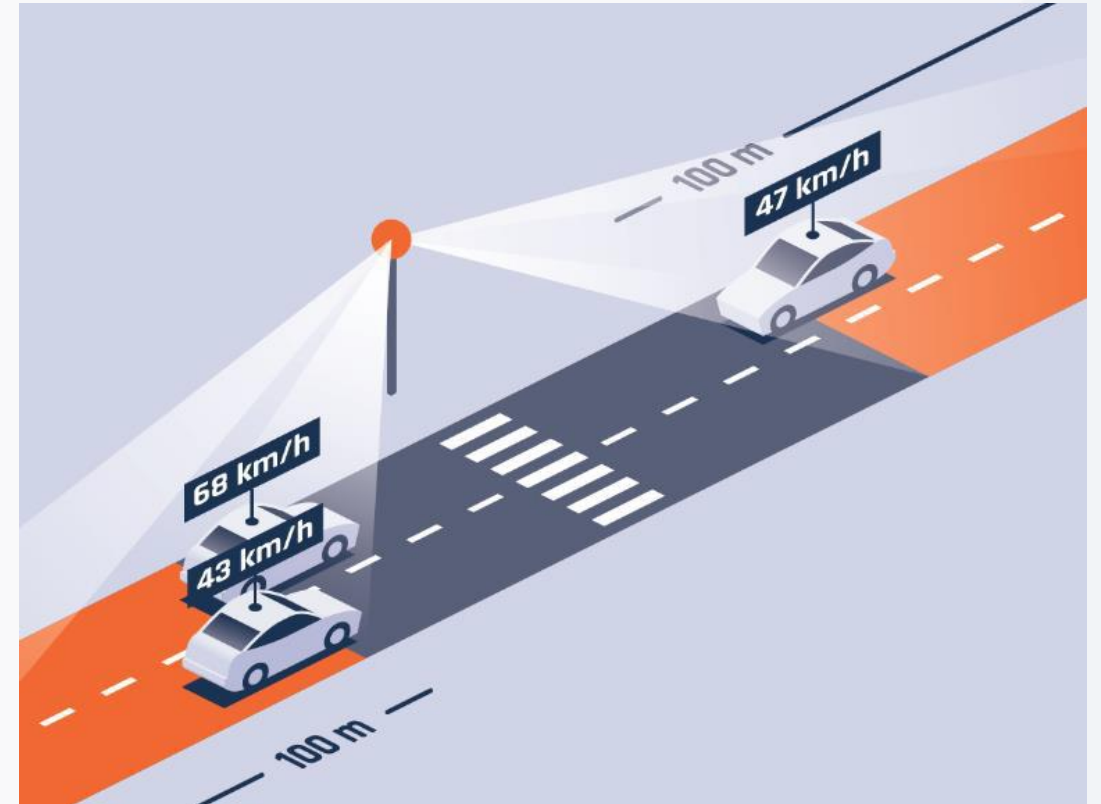
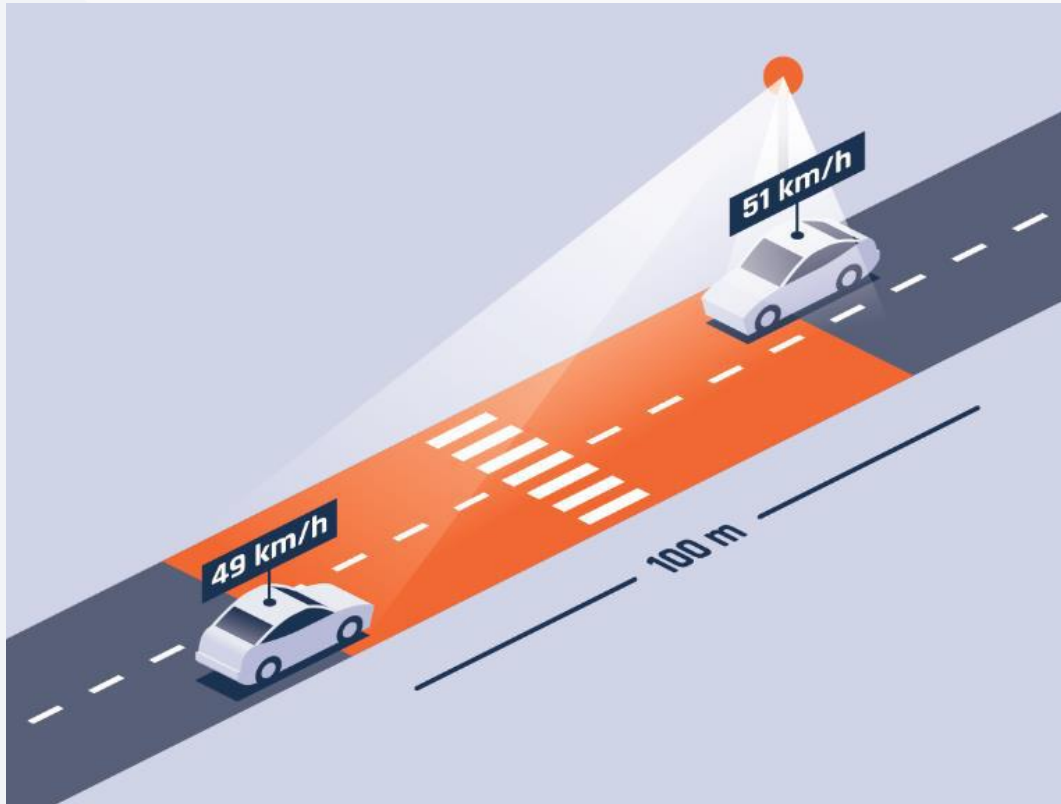

# Radar Speed Enforcement Use Cases

Road safety at road intersections.

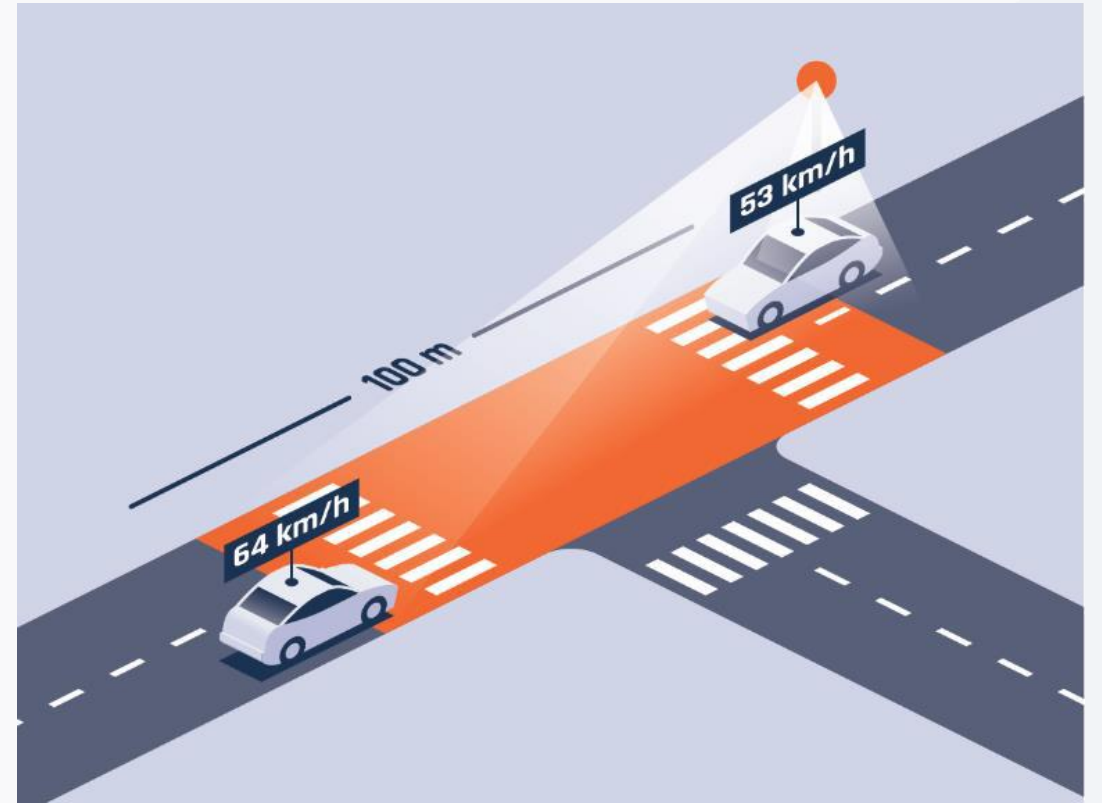
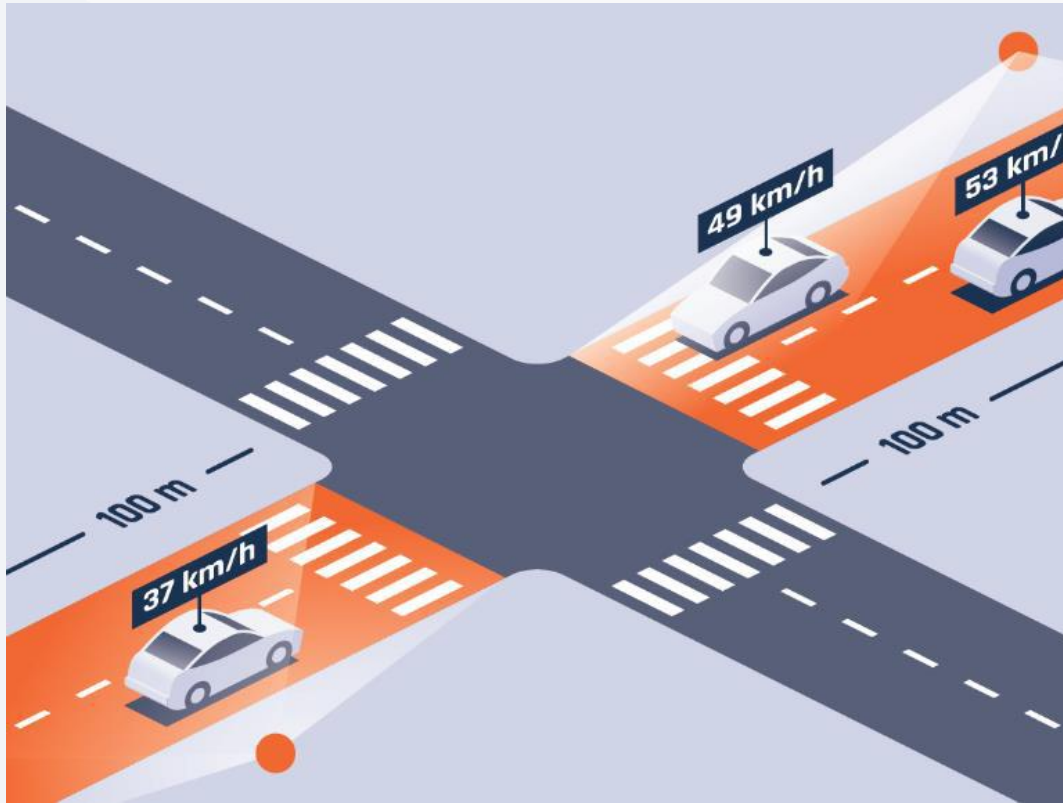

# Radar Speed Enforcement Installation Examples

Installation at pedestrian crossings and intersections in towns and cities.



# Radar Speed Enforcement Installation Examples

Installation at pedestrian crossings and intersections in towns and cities.



# Type Approval

- Speed enforcement using a 3D/4D radar.
- Version 1
  - Measurement of current speed.
  - First type approved in 2019 in the Czech Republic.
  - Currently valid until March 14, 2029.
- Version 2
  - Measurement of both the current and section speed in a short section (up to 100 m).
  - First type approved in 2023 in the Czech Republic.
  - Currently valid until October 8, 2033.
- Type approval under way in Slovakia.



# Section Speed Enforcement

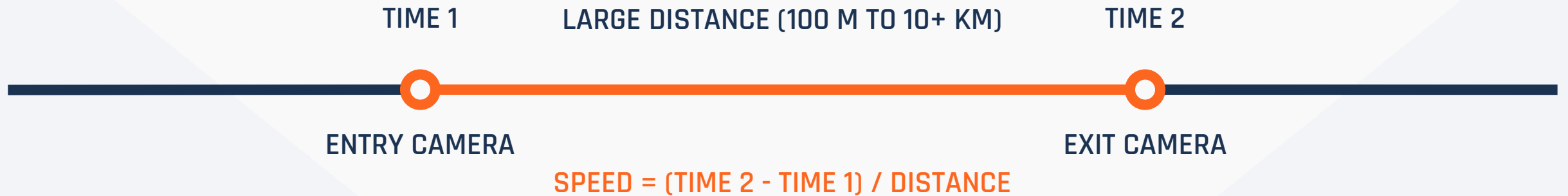

- Additional Requirements: HW (entry and exit) and SW licenses
- Used Technology: ANPR cameras at entry and exit points
- Principle: Measurement of the time difference over a known distance between the entry and exit points. Existing systems with ANPR cameras can be used as the points. Multiple sections can be linked and chained.

# Section Speed Enforcement Principle

ANPR Camera at Section Entry Point



ANPR Camera at Section Exit Point



# Type Approval

- Section speed enforcement.
- First type approved in 2003 in the Czech Republic, in 2013 in Poland, 2015 in Italy.
- Currently valid in CZ until December 4, 2033.
- Type approval under way in Slovakia.



# Combining Section Speed and Other ITS



## Radar Speed Enforcement

- Using radar cameras as an entry or exit point of the section.
- The radar camera also works as a place of current speed measurement.
- For example, to measure the speed of vehicles approaching the point from which the section speed of vehicles will be measured.

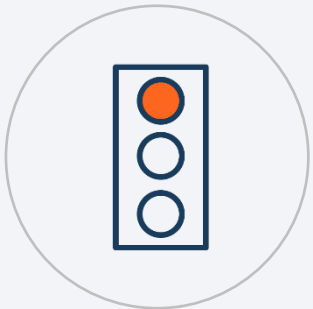

## Red Light Enforcement

- Combination of detection and documentation of red-light violations together with speed measurement in the intersection or pedestrian crossings.
- This station can also be used as an entry or exit point of the section.

# Combining Section Speed and Other ITS



## WIM Stations

- Using WIM stations as an entry or exit point of the section.
- The WIM station also works as a place of current speed measurement.
- The section speed can also be measured between two WIM stations without any additional HW.



## Chaining Multiple Sections

- Multiple points can be chained to create multiple sections with high variability.
- Example: points A, B, and C can form sections A-B, B-C, A-C and so on.
- For example, a whole city ring road can be monitored (not just one location, as is the case with radar).

# Combining Current and Section Speed

Using the current speed measurement system as an entry to the section.

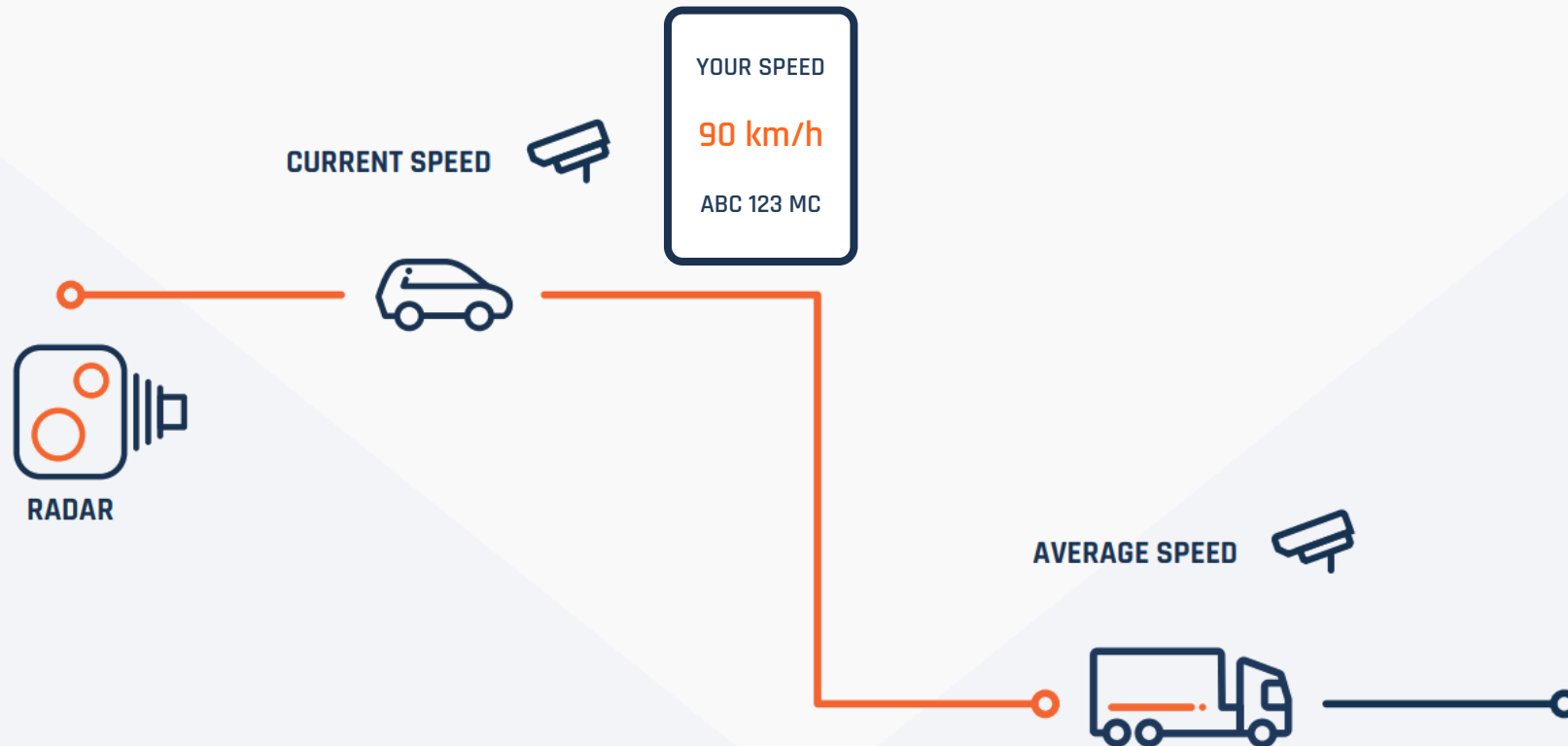

# Combining Current and Section Speed

ANPR Camera with Radar at Section Entry Point

ANPR Camera at Section Exit Point



**camea**

Intelligent Transportation Systems

# Speed Enforcement Installation Options

[www.cameatechnology.com](http://www.cameatechnology.com)

# ANPR Camera Installation Options



**GANTRIES**



**POLES**



**PORTABLE  
HALF-GANTRIES**



**PORTABLE  
TRAFFIC SIGNALS**

# Installation on Gantries

Highways, ring roads, toll gates.



# Installation on Poles

Urban or rural roads and highways, cities, towns, villages, public lighting.



# Installation on Portable Half-Gantries

During road closures, temporary measurement by alternating direction.



# Installation on Portable Traffic Signals



**VEHICLE-MOUNTED  
TRAFFIC SIGNS**



**SPEED SIGN  
TRAILERS**

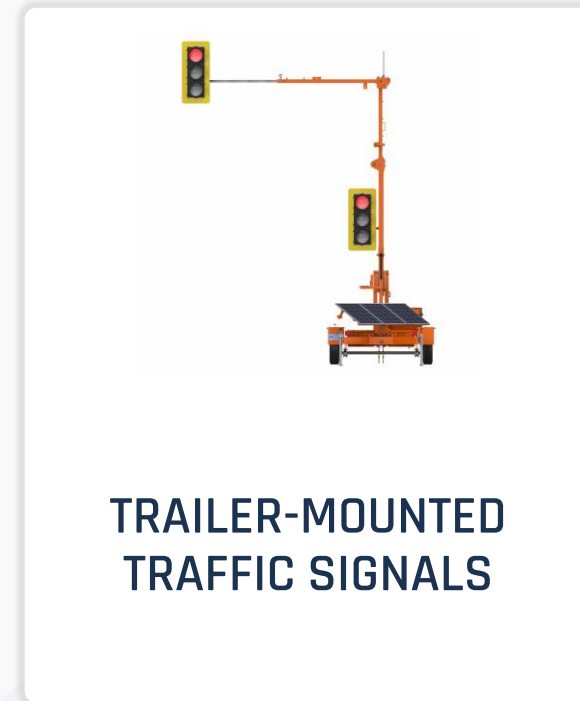

**TRAILER-MOUNTED  
TRAFFIC SIGNALS**

**camea**

Intelligent Transportation Systems

# Speed Enforcement Violation Processing

[www.cameatechnology.com](http://www.cameatechnology.com)

# Speed Enforcement Violation Processing 1/5

The violation is detected, evaluated and documented.



# Speed Enforcement Violation Processing 2/5

An offence document is generated and sent to the authorities.



# Speed Enforcement Violation Processing 3/5

The operator validates the offence - checks the license plate.



# Speed Enforcement Violation Processing 4/5

The operator validates the offence - checks the vehicle class.

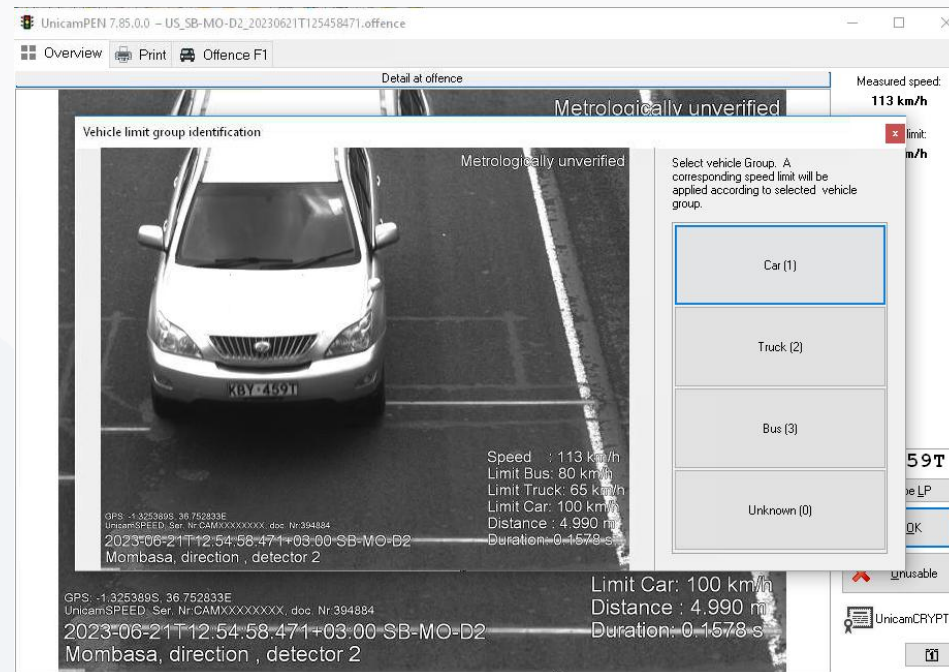

# Speed Enforcement Violation Processing 5/5

The operator prints the offence.



**camea**

Intelligent Transportation Systems

# Speed Enforcement Possible Extensions

[www.cameatechnology.com](http://www.cameatechnology.com)

# Examples of Extensions of the Camera Systems

The camera system can easily be extended using additional SW modules.

- ✔ Traffic Counting / Make and Model Recognition
- ✔ Monitoring of Dedicated Bus/Taxi Traffic Lanes
- ✔ Detection of Driving without Headlights at Night, Driving in Wrong Direction
- ✔ Vehicle Tracing - Journey Time Estimations, Traffic Studies, Searches for Stolen Vehicles
- ✔ Driver's Face - External Light Unit may be necessary
- ✔ Dangerous Goods - ADR Label Reading
- ✔ and many more...

# Monitoring of Dedicated Bus Traffic Lanes

Video recording of the overall situation on the road (example from Prague, Evropská Street, Czech Republic, 2023/04/11)

